

CAP BALANCER Type-BX

Title		Assembly Drawing BX-100	
Drawing No.		K-BX100-161E Rev. 1	
DRAWN BY	NAME	DATE	1 / 1
CHECKED BY	K.Kawakami	2016/04/15	SHEET SIZE A4
APPROVED BY	KANTEC Co.,Ltd.		

Material: SCS13 & SUS304
(Excluding Springs & Bushes)

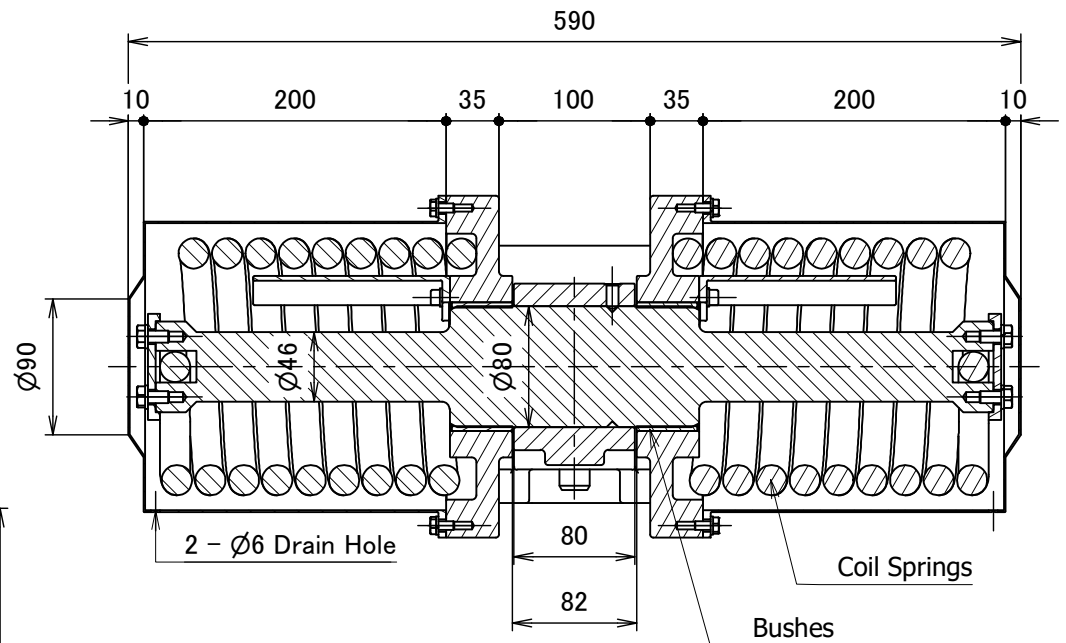
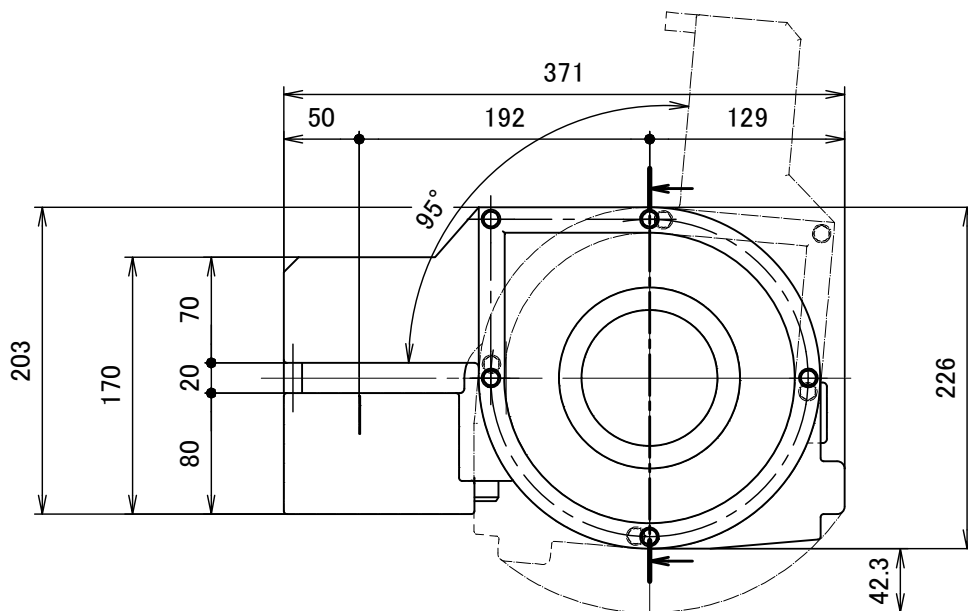
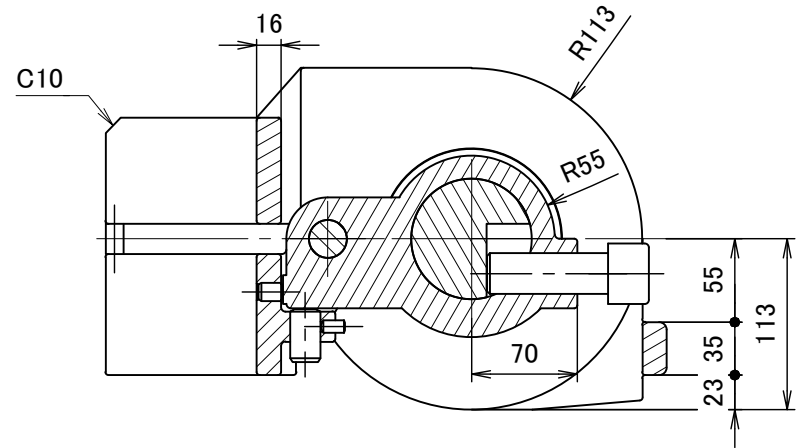
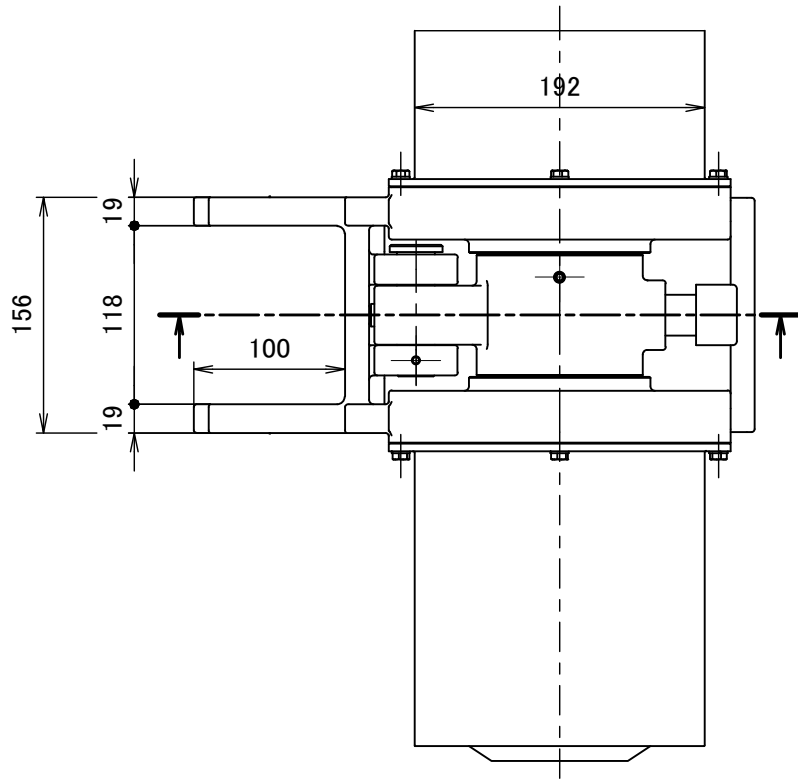

Material: SCS13 & SUS304
(Excluding Springs & Bushes)

CAP BALANCER BX-125

Title		Assembly Drawing BX-125	
Drawing No.		K-BX125-161E Rev. 1	
DRAWN BY	NAME	DATE	1 / 1
CHECKED BY	K.Kawakami	2016/04/15	SHEET SIZE A4
APPROVED BY	KANTEC Co.,Ltd.		